



**ADDENDUM NO. 001**

**TO:** All Plan Holders

**RE:** Sullivan County Department of Education – Ketron Elem. School Partial Roof Replacement  
T&L Project No. 17118

**DATE:** March 3, 2023

**BIDS RECEIVED DATE:** March 15, 2023

This Addendum forms a part of the Contract Documents and modifies the original Bidding Documents dated February 10, 2023, as noted below. Acknowledge receipt of this Addendum in the space provided on the Bid Form. Failure to do so may subject Bidder to disqualification.

This Addendum consists of 7 pages, 3 drawing sheets, and 1 specification page with the revised date of March 3, 2023.

**CLARIFICATIONS AND ANSWERS TO PRE-BID QUESTIONS:**

1. The Pre-Bid Conference Attendance Record is enclosed.
2. The Pre-Bid Conference Meeting Minutes are enclosed.
3. **Bid Form** – Revised to include Alternate #1

**CHANGES TO DRAWINGS:**

1. Drawing Sheets AD101, A101, & A102 are revised to added alternate #1 with details and notes.

Enclosures: Drawing Sheets D100, A100, & A101 and Specification Section 01 2300.



THOMPSON & LITTON

PRE-BID CONFERENCE  
ATTENDANCE RECORD

Wednesday, March 01, 2022 AT 10:00 A.M.

Sullivan County Department of Education - Ketrone Elem. Partial Roof Project  
For

Sullivan County Department of Education  
T&L Project No. 17118

NAME	COMPANY	WORK NUMBER	MOBILE NUMBER	EMAIL ADDRESS
Mary Darnell	Thompson and Litton	423-989-0403		mdarnell@t-l.com
Terry Miller	Dixie Roofing, Inc.	938-9880 <del>865-388-0341</del>	865-388-0341	terry@dixieroofinginc.com
Michelle Ramey	Sullivan County	423-323-6480		Michelle.Ramey@sullivancountytn.gov
CHARLES HUBBARD	SCDE	423-354-1151	423-817-2022	CHARLES.HUBBARD@SULLIVANK12.NET
Mardy Roberts Jr	Todd Harkle Road Roofing	423-265-6059		Efrimarking@tfrroof.com
Son Brewer	Carlisle (Apex Roof)	423-217-5301		son@apexroof.com



**THOMPSON  
& LITTON** EST.  
1956

ENGINEERS ARCHITECTS SURVEYORS

## PRE-BID CONFERENCE AGENDA

**PROJECT:** Sullivan County Department of Education – Ketron Elem. Partial Roof Project  
T&L Project No. 17118

**DATE:** March 1, 2023

**1. PROJECT PERSONNEL:**

Architectural/Engineering Firm: Thompson & Litton, Inc.

Architectural/ Representative & Project Manager: Mary Darnell

Telephone: (423) 989-9491

**2. SCOPE OF PROJECT:**

The project scope includes a partial roof replacement at Ketron Elementary School above the kitchen. The existing built-up roof will be removed and prepared for a new roof. The new 3,776 square foot roof consists of a new membrane over new tapered insulation on the existing roof deck. Replacement of the existing gutters and downspouts is also required.

**3. SPECIAL SITE/PROJECT CONDITIONS:**

Working during school hours coordination with principal.

Testing for asbestos – report required of findings.

**4. CONTRACT(S) DETAILS:**

Follow the Bid Evaluation Checklist.

Davis Bacon Wages

Allowances: As indicated in specification section 01 2100. All remaining allowance funds not utilized will be credited back to the owner.

Liquidated Damages: \$200.00/ per Day after Sept. 30,2023



**5. BID DOCUMENTS:**

Bid Documents (electronic and/or hard copy) are available for purchase through Knoxville Builders Exchange or AGC Plan Room.

**6. CONFIRMATION OF BID DATE AND TIME:**

Sealed bids will be received until **2:00 P.M.**, prevailing time on **March 15, 2023**, by the Sullivan County Purchasing Agent at the Sullivan County Courthouse, 3411 highway 126, Suite 201, Blountville, TN.

**7. CONTRACTOR QUESTIONS:**

All questions must be submitted in writing using the Pre-Bid Question Form provided in the Bid Documents. Instructions for submission (via email or fax) are included on the form. Responses to questions, if deemed necessary, will be made via addendum(a).

Deadline (Date/Time) for Submitting Questions: March 8<sup>th</sup>, 2023 at 5:00 pm

Ketron Elementary School Partial Roof Replacement  
Blountville, TN

## B I D F O R M

TO:                           OWNER:           Sullivan County Tennessee  
                                  ADDRESS:       3411 Highway 126  
  Blountville, TN 37617

BID TRANSMITTED IN CARE OF:   Michelle Ramey, Chief Deputy Purchasing Agent  
  Sullivan County Courthouse  
  3411 Highway 126  
  Blountville, TN 37617

FROM: BIDDER: \_\_\_\_\_

ADDRESS: \_\_\_\_\_

CITY/STATE/ZIP: \_\_\_\_\_

TELEPHONE: \_\_\_\_\_

TN. LICENSE NO: \_\_\_\_\_

LICENSE EXPIRATION DATE: \_\_\_\_\_

THE ABOVE STATED BIDDER IS:

\_\_\_\_\_ AN INDIVIDUAL

\_\_\_\_\_ A CORPORATION

\_\_\_\_\_ A PARTNERSHIP

\_\_\_\_\_ A JOINT VENTURE CONSISTING OF:

\_\_\_\_\_

\_\_\_\_\_

\_\_\_\_\_

AND IS LICENSED TO DO BUSINESS IN THE STATE OF TENNESSEE,  
FOR THE WORK SPECIFIED.

Ketron Elementary School Partial Roof Replacement  
Blountville, TN  
GENTLEMEN:

1. Having examined the plans and specifications, having visited the site of the proposed work, and being completely familiar with the local conditions affecting the cost of the work, and having carefully examined the construction bidding documents with addenda prepared by Cain Rash West Architects and entitled "KETRON ELEMENTARY SCHOOL PARTIAL ROOF REPLACEMENT"

2. I, (We) propose to execute the portion of the work identified as "**Ketron Elementary School Partial Roof Replacement**" for the stipulated sum, **including allowances as indicated in specification section 01 2100 – Allowances, and in accordance with drawings and specifications. Remaining allowance funds not utilized on the project will be credited back to the owner:** (sums shall be in written and numerical form)

Lump Sum Base Bid \_\_\_\_\_ DOLLARS  
(\$ \_\_\_\_\_).

**Add Alternate #1:** Lump Sum \_\_\_\_\_ DOLLARS  
(\$ \_\_\_\_\_).

Proposed Project Duration \_\_\_\_\_ ( \_\_\_\_\_ ) Days  
(Notice to Proceed to Completion of Project)

**Liquidated Damages shall be \$200 per day after September 30, 2023 if not substantially Complete. Note: Owner is aware of material availability issues – if all reasonable efforts to obtain materials have been made and documented and are not available to complete the project on time, the contractor will not be penalized.**

3. The undersigned agrees to complete all of the work described by the "Contract Documents" and have the space fully ready for occupancy, including any Alternates.
4. The undersigned agrees to commence work under this contract within three working days of receipt of Notice to Proceed.
5. The undersigned agrees that this bid shall be good and may not be withdrawn for a period of (30) thirty calendar days after the scheduled closing time for receiving bids.
6. The undersigned, upon receipt of written notice of the acceptance of this bid, agrees to deliver, to the owner or his agent, the architect, the required performance bond, labor and material payment bond and certificate of insurance in accordance with the specifications and instructions to bidders.

Ketron Elementary School Partial Roof Replacement  
Blountville, TN

The undersigned hereby acknowledges receipt of:

ADDENDUM NO.	DATE
_____	_____
_____	_____
_____	_____

This proposal is respectfully submitted

By: \_\_\_\_\_

Title: \_\_\_\_\_

Firm name: \_\_\_\_\_

\_\_\_\_\_

Business address: \_\_\_\_\_

\_\_\_\_\_

\_\_\_\_\_  
(Seal if this bid is submitted by a Corporation)

This Bid Form consists of Three (3) pages.  
END OF BID FORM



PARTIAL ROOF REPLACEMENT FOR:  
**KETRON ELEMENTARY SCHOOL**  
 KINGSFORD, TENNESSEE  
**DEMOLITION ROOF PLAN**

No.	1
Date	3/3/2023
Purpose of Document Issue	ALTERNATE #1 & ADDED DETAILS/NOTES

Designed	MD
Drawn	MD
Checked	NES
Date	FEBRUARY 10, 2023

Project No. 17118



Sheet No. AD101

**ABBREVIATIONS :**

- E.D.S. EXISTING DOWNSPOUTS
- E.R.V. EXISTING ROOF VENTS
- E.E.F. EXISTING EQUIPMENT FAN
- E.GAS EXISTING GAS LINE
- E.B.U.R. EXISTING BUILT UP ROOF
- E.G.V. EXISTING GAS VENTS

**GENERAL DEMOLITION ROOF NOTES: (X)**

1. DEMO EXISTING GRAVEL ON BUILT UP ROOF AND INSULATION DOWN TO EXISTING GYPSUM DECK. INSPECT FOR ANY DAMAGED GYPSUM AND REPAIR. FIELD VERIFY AND PREPARE FOR NEW TAPERED INSULATION AND FULLY ADHERED TPO MEMBRANE.
2. DEMO EXISTING GUTTER, GRAVEL STOP EDGE, DOWNSPOUTS. PREPARE ARE FOR NEW GUTTER AND DOWN SPOUT.
3. EXTEND ALL EXISTING VENT PIPES AS REQUIRED TO MEET 12" MINIMUM HEIGHT - SEE DETAILS 2/A102 - TYPICAL ENTIRE ROOF.
4. FOR ALL EXISTING MECHANICAL UNITS, EXHAUST FAN UNITS, GRAVITY VENTS WITH CURBS, ETC. : SEE DETAIL 3/A102 - ALL CURBS TO RECEIVE NEW CRICKET AS REQUIRED ON HIGH SIDE OF ROOF - TYPICAL ENTIRE ROOF.
5. EXISTING GAS LINE: WHEN INSTALLING ROOF RAISE GAS LINE & SUPPORTS AS REQUIRED.

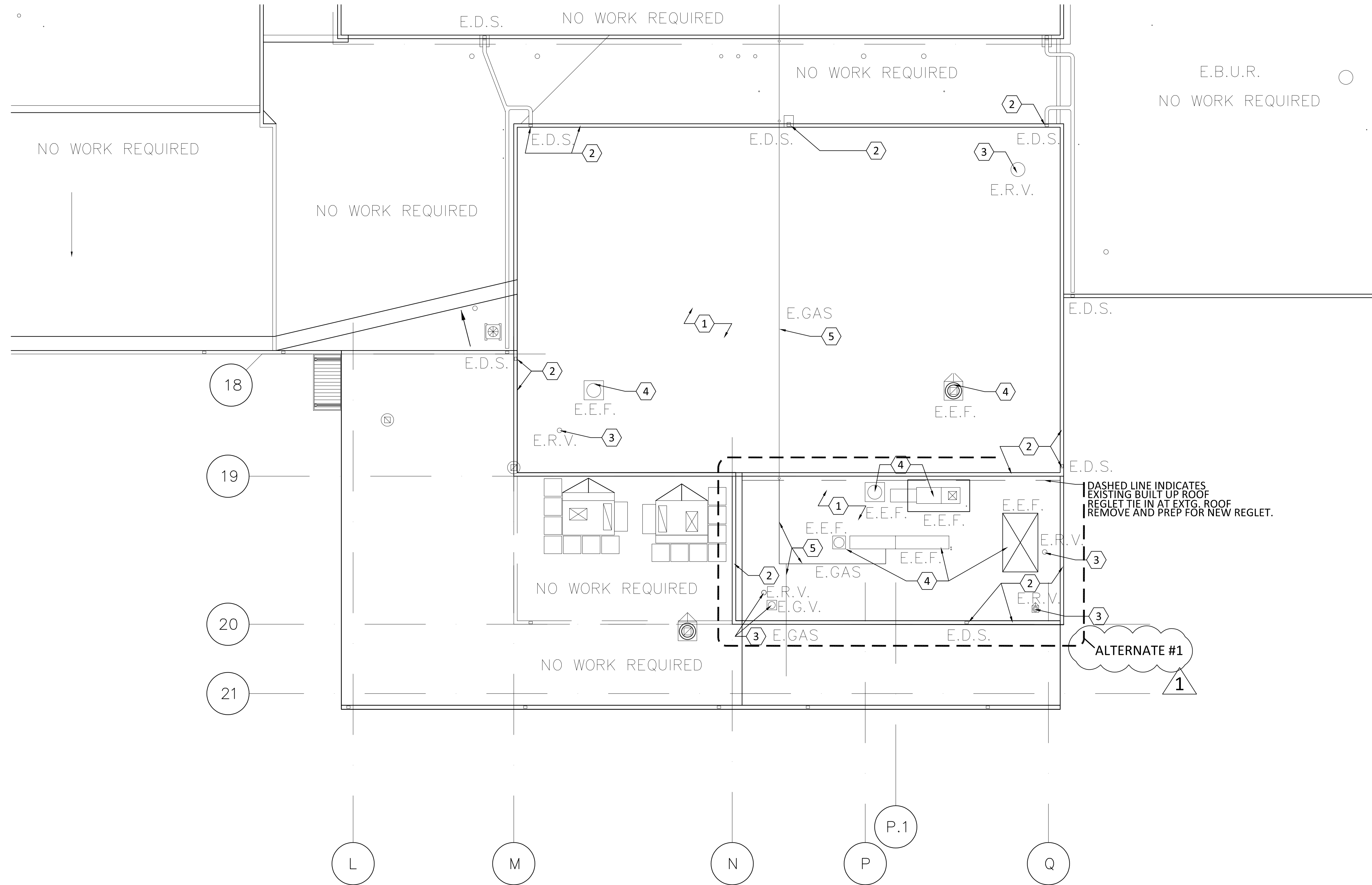

DASHED LINE INDICATES EXISTING BUILT UP ROOF REGLET TIE IN AT EXTG. ROOF REMOVE AND PREP FOR NEW REGLET.

ALTERNATE #1

**ROOF DEMOLITION PLAN**  
 SCALE: 1/8"=1'-0"

1  
 AD101/AD101



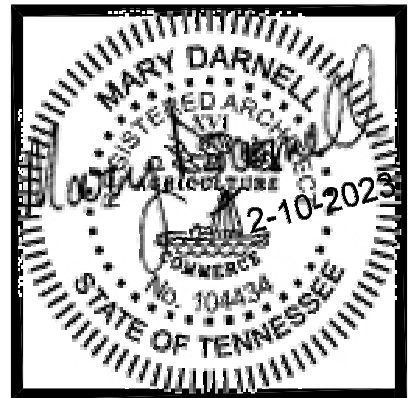

PARTIAL ROOF REPLACEMENT FOR:  
**KETRON ELEMENTARY SCHOOL**  
 KINGSPORT, TENNESSEE  
**ROOF PLAN**

Purpose of Document Issue	
No.	ALTERNATE #1 & ADDED DETAILS/NOTES
Date	3/3/2023
No.	1

Designed	MD
Drawn	MD
Checked	NES
Date	FEBRUARY 10, 2023

Project No. 17118



Sheet No. **A101**

**ABBREVIATIONS :**

- D.S. NEW DOWNSPOUTS
- E.R.V. EXISTING ROOF VENTS
- E.E.S. EXISTING EQUIPMENT FAN
- E.GAS EXISTING GAS LINE
- E.G.V. EXISTING GAS VENT

**GENERAL ROOF NOTES: (X)**

1. INSTALL NEW FULLY-ADHERED SINGLE-PLY TPO 60 MIL MEMBRANE ROOF ON NEW 1" MIN. TAPERED INSULATION BOARD 1/4" PER 1'-0" SLOPE WITH POSITIVE DRAINAGE ON EXISTING ROOFING SUBSTRATE.
2. INSTALL NEW GUTTERS AND DOWNSPOUTS - SEE DETAIL 1/A102. INSTALL NEW DOWNSPOUT SPLASH BLOCKS AS REQUIRED.
3. EXTEND ALL EXISTING VENT PIPES AS REQUIRED TO MEET 12" MINIMUM HEIGHT - SEE DETAILS 2/A102 - TYPICAL ENTIRE ROOF.
4. FOR ALL EXISTING MECHANICAL UNITS, EXHAUST FAN UNITS, GRAVITY VENTS WITH CURBS, ETC.: SEE DETAIL 3/A102 - ALL CURBS TO RECEIVE NEW CRICKET AS REQUIRED ON HIGH SIDE OF ROOF - TYPICAL ENTIRE ROOF.
5. EXISTING GAS LINE: WHEN INSTALLING ROOF RAISE GAS LINE AS REQUIRED.
6. INSTALL NEW REGLET AT EXISTING MASONRY PARAPET WALL. SEE DETAIL 4/A102.

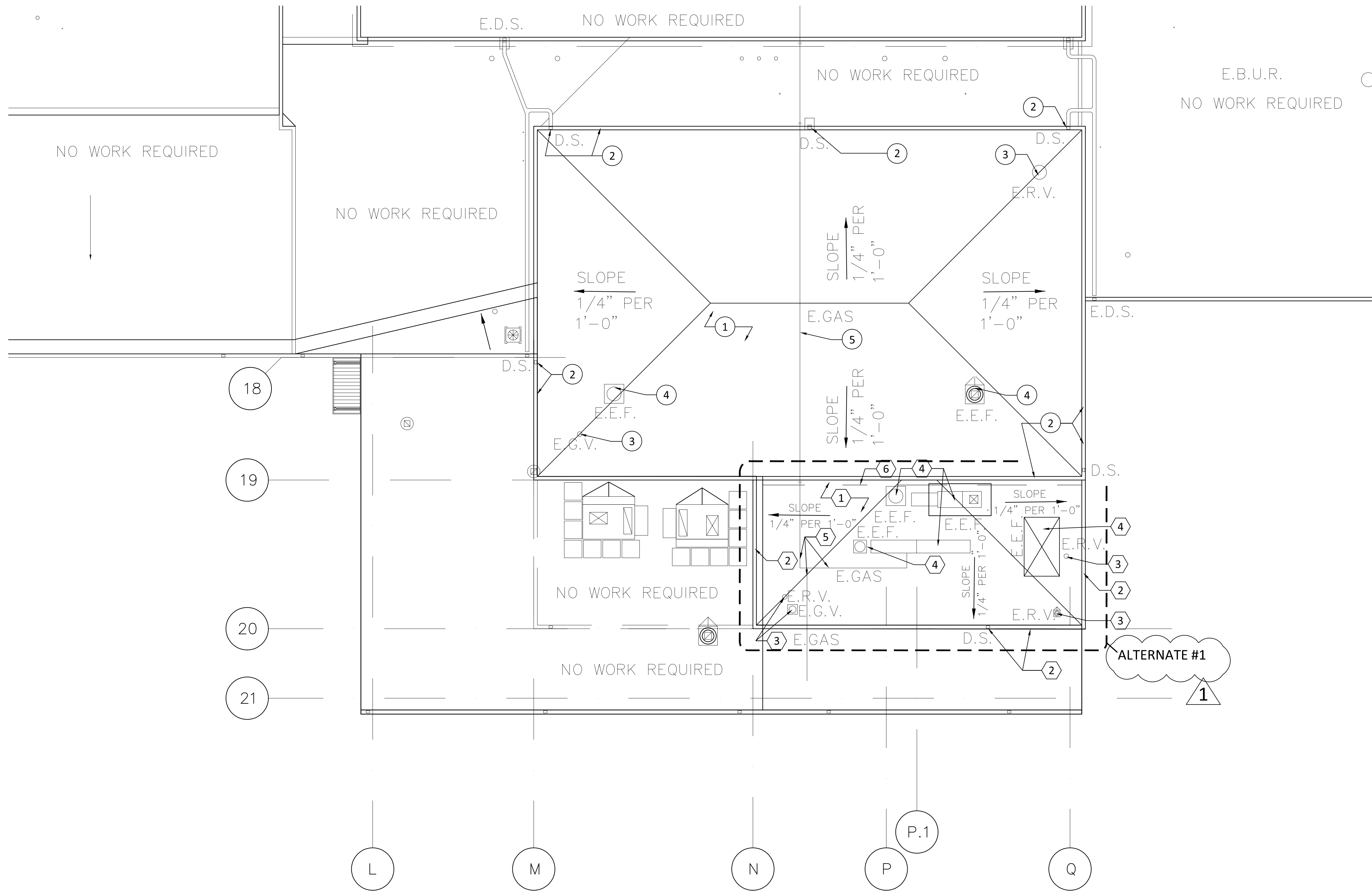

**ROOF PLAN**  
SCALE: 1/8"=1'-0"

1  
A101A101

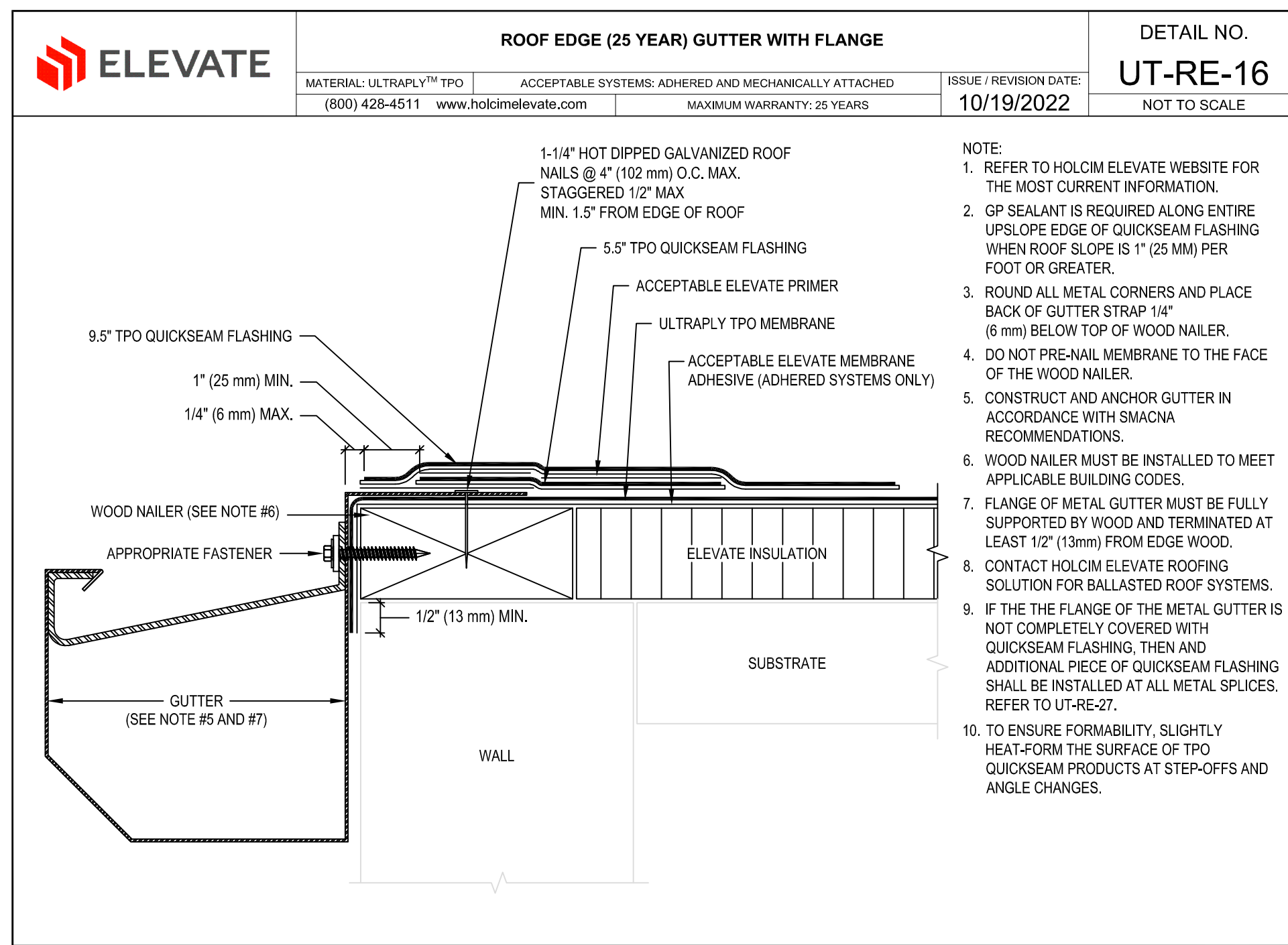

DETAIL NO.  
**UT-RE-16**

ROOF EDGE (25 YEAR) GUTTER WITH FLANGE



- NOTE:
- REFER TO HOLCIM ELEVATE WEBSITE FOR THE MOST CURRENT INFORMATION.
  - GP SEALANT IS REQUIRED ALONG ENTIRE UPSLOPE EDGE OF QUICKSEAM FLASHING WHEN ROOF SLOPE IS 1" (25 MM) PER FOOT OR GREATER.
  - ROUND ALL METAL CORNERS AND PLACE BACK OF GUTTER STRAP 1/4" (6 mm) BELOW TOP OF WOOD NAILER.
  - DO NOT PRE-NAIL MEMBRANE TO THE FACE OF THE WOOD NAILER.
  - CONSTRUCT AND ANCHOR GUTTER IN ACCORDANCE WITH SMACNA RECOMMENDATIONS.
  - WOOD NAILER MUST BE INSTALLED TO MEET APPLICABLE BUILDING CODES.
  - FLANGE OF METAL GUTTER MUST BE FULLY SUPPORTED BY WOOD AND TERMINATED AT LEAST 1/2" (13mm) FROM EDGE WOOD.
  - CONTACT HOLCIM ELEVATE ROOFING SOLUTION FOR BALLASTED ROOF SYSTEMS.
  - IF THE FLANGE OF THE METAL GUTTER IS NOT COMPLETELY COVERED WITH QUICKSEAM FLASHING, THEN AN ADDITIONAL PIECE OF QUICKSEAM FLASHING SHALL BE INSTALLED AT ALL METAL SPLICES. REFER TO UT-RE-27.
  - TO ENSURE FORMABILITY, SLIGHTLY HEAT-FORM THE SURFACE OF TPO QUICKSEAM PRODUCTS AT STEP-OFFS AND ANGLE CHANGES.

- NOTES:
- REMOVE ALL LEAD AND OTHER FLASHING
  - PRE-MOLDED PIPE SEAL CAN NOT BE CUT VERTICALLY TO BE INSTALLED
  - DECK FLANGE CAN NOT BE TRIMMED
  - WHEN PRE-FABRICATED PIPE SEAL CAN NOT BE INSTALLED, USE FIELD-FABRICATED PIPE SEAL.
  - PRE-MOLDED PIPE SEAL MUST HAVE INTACT RIB AT TOP EDGE, REGARDLESS OF PIPE DIAMETER.
  - APPLY IN-SEAM SEALANT 1/2 INCH FROM THE INSIDE EDGE OF THE PIPE SEAL FLANGE

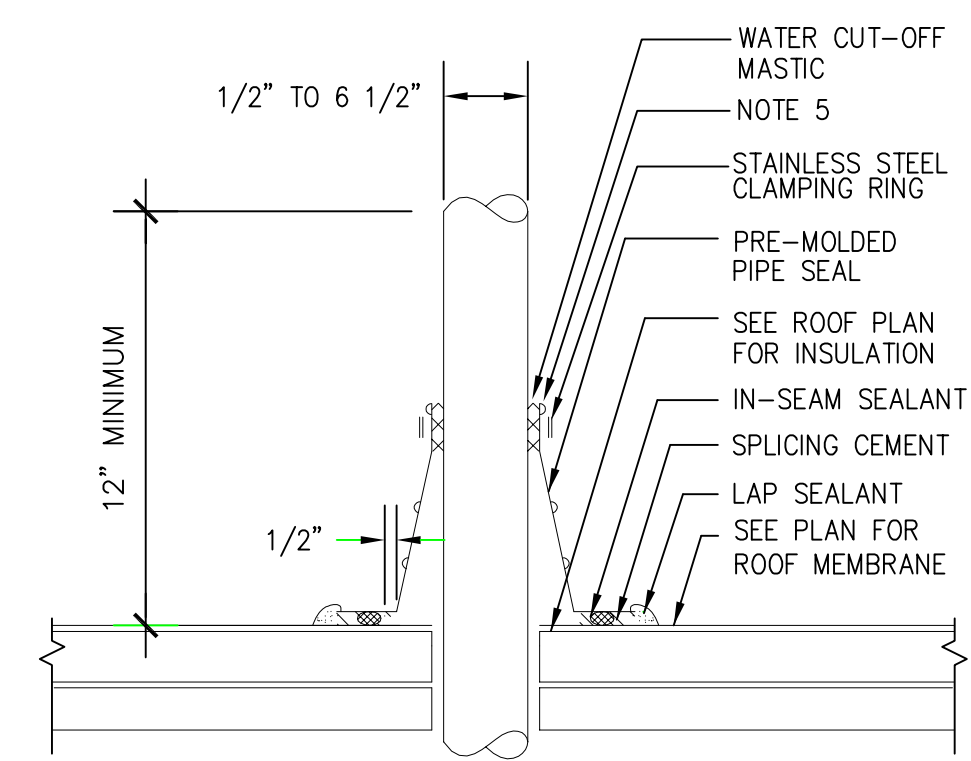

2 PRE-MOLDED VENT PIPE FLASHING  
SCALE: NONE

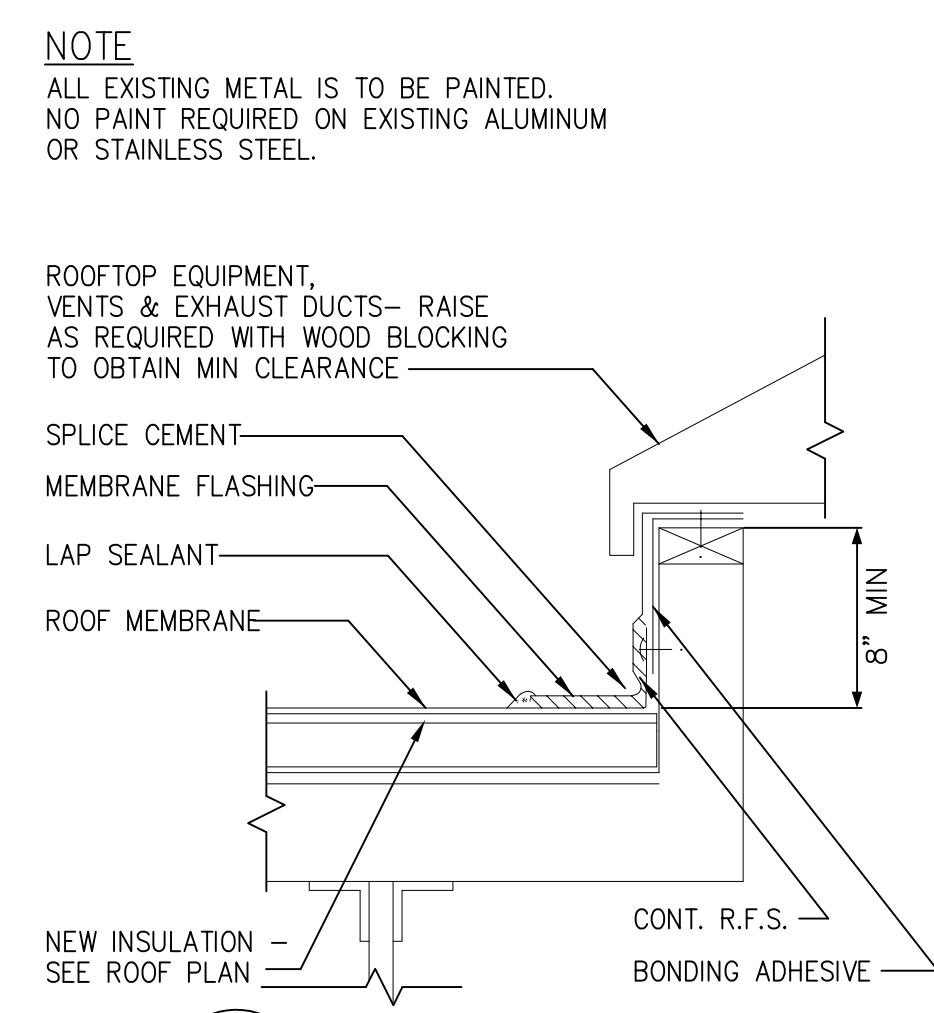

3 CURB DETAIL  
SCALE: 1 1/2"=1'-0"

1 ROOF EDGE DETAIL  
A102

NOTE: PROVIDE BLOCKING FOR ROOF EDGE AS REQUIRED.

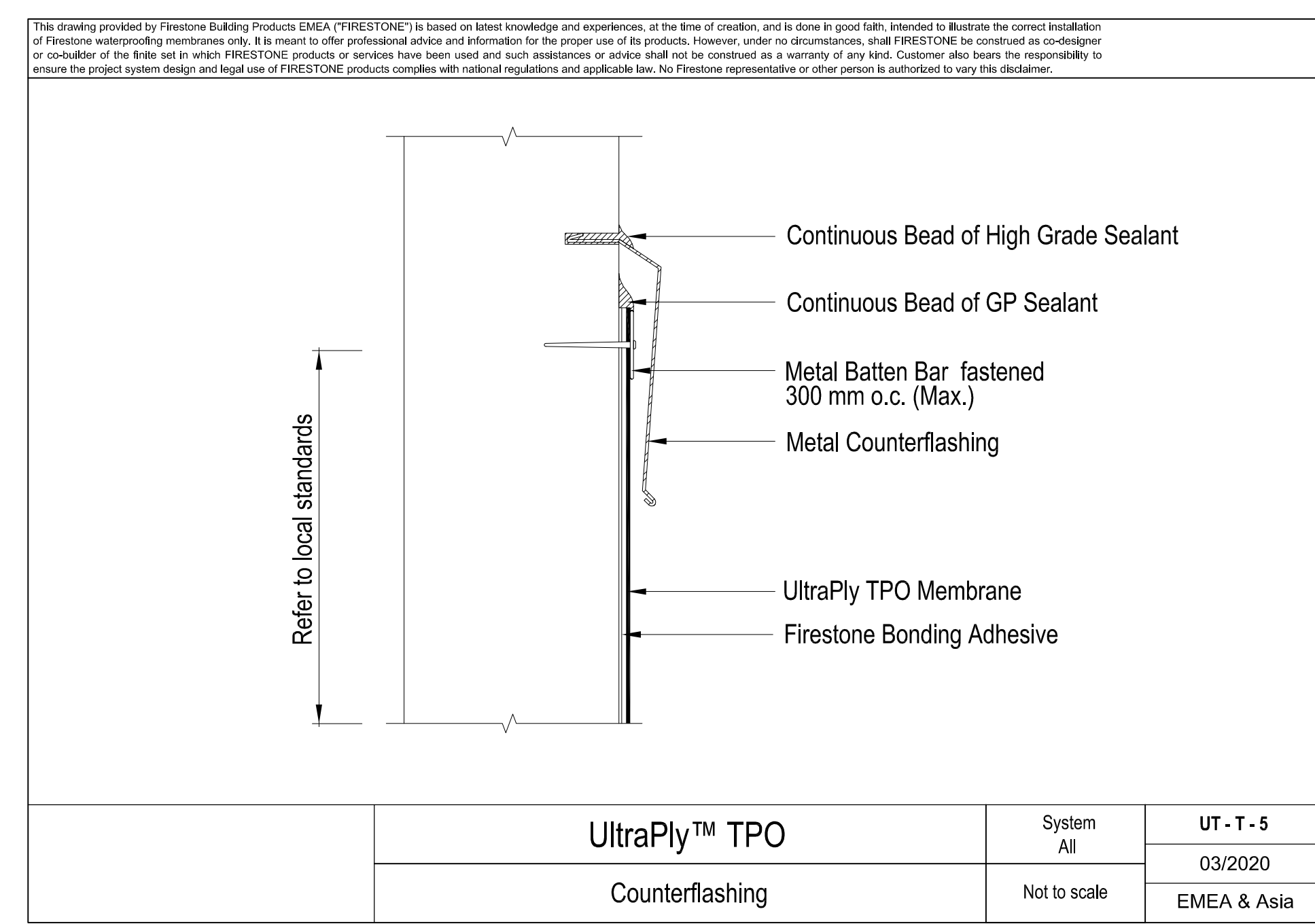

4 REGLET DETAIL  
A102 NOTE: VERIFY WEEP VENT LOCATION AND DO NOT COVER.

UltraPly™ TPO	System	UT - T - 5
Counterflashing	All	03/2020
	Not to scale	EMEA & Asia

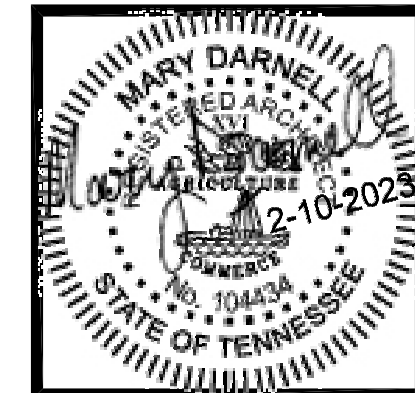

PARTIAL ROOF REPLACEMENT FOR:  
**KETRON ELEMENTARY SCHOOL**  
KINGSPORT, TENNESSEE

**ROOF DETAILS**

No.	1	Purpose of Document Issue	ALTERNATE #1 & ADDED DETAILS/NOTES
Date	3/3/2023		

Designed	MD
Drawn	MD
Checked	NES
Date	FEBRUARY 10, 2023

Project No.  
**17118**



Sheet No.  
**A102**

## **SECTION 01 2300 - ALTERNATES**

### **PART 1 GENERAL**

#### **1.1 SECTION INCLUDES**

- A. Section includes administrative and procedural requirements for pricing Alternates.

#### **1.2 DEFINITIONS**

- A. Alternate: An amount proposed by bidders and stated on the Bid Form for certain work defined in the Bidding Requirements that may be added to or deducted from the base bid amount if Owner decides to accept a corresponding change either in the amount of construction to be completed or in the products, materials, equipment, systems, or installation methods described in the Contract Documents.
  - 1. Alternates described in this Section are part of the Work only if enumerated in the agreements.
  - 2. The cost or credit for each alternate is the net addition to or deduction from the contract Sum to incorporate alternate into the Work. No other adjustments are made to the Contract Sum.

#### **1.3 ACCEPTANCE OF ALTERNATES**

- A. Alternates quoted on Bid Forms will be reviewed and accepted or rejected at Owner's option. Accepted Alternates will be identified in the Owner-Contractor Agreement.
- B. Coordinate related work and modify surrounding work to integrate the Work of each Alternate.

#### **1.4 SCHEDULE OF ALTERNATES**

- A. Add Alternate No. 1: Lower Existing Built up roof to be replaced. Refer to drawings for details and extend of scope of work.

### **PART 2 PRODUCTS - NOT USED**

### **PART 3 EXECUTION - NOT USED**

**END OF SECTION**